

Chapter 4

Bridge Program Drawings

Section 4.18-Miscellaneous Hydraulic Structures

Introduction

Miscellaneous hydraulic structures include siphons and flumes. Either single or multiple barrel siphons or flumes may be used at a particular location. Historically, smooth steel, corrugated steel, plastic pipe, or concrete pipe is used in the construction of siphons and smooth steel pipe is used in the construction of water transport flumes.

Stilling basins, energy dissipators, diversion boxes, and various inlet and outlet structures may be constructed in conjunction with hydraulic structures in order to control and regulate the flow of water. These may vary in size and shape depending on the intended use.

Miscellaneous Hydraulic Structure Types

SIPHONS are jointed pipes used to transport water from ditch to ditch, usually from right-of-way to right-of-way, underneath a road, highway, or other obstruction when gradeline precludes using a culvert. A siphon may be either a full or a half siphon.

FULL SIPHONS have three or more pipes joined together allowing each of the pipes to be sloped differently to achieve desired cover, slopes, or other criteria.

HALF SIPHONS are composed of two pipes joined together allowing each of the pipes to be sloped differently to achieve desired cover, slopes, or other criteria.

WATER TRANSPORT FLUMES are pipes used to transport water from ditch to ditch, usually from right-of-way to right-of-way, above a road, highway, or other obstruction.

PARSHALL MEASURING FLUMES (or weirs) are manufacturer supplied, constricted throat devices used in open ditches to calculate the volume of water moving through the ditches during a specific time interval.

General Design and Detail Information Siphons

The basic geometry; pipe size, material type, and style; and location of a siphon is determined by the Hydraulic Section during the course of their analysis and will be included in the Hydraulic Report.

Design engineers and detailers will be responsible for making slight adjustments to the basic geometry. Modifications may be required due to buried utilities, changes to right-of-way width, and road cross sections, location of road underdrains, drain box requirements, and field recommendations. Any significant changes in the vertical distance between the inlet and outlet (head) must be discussed with the hydraulic engineer.

The entire **SIPHON PIPE** will be located within the right-of-way (except as requested by the field). The pipes may vary in diameter from site to site, but the pipes at any one siphon will be the same diameter. The grade on any pipe comprising the siphon pipe will be no less than one-half of one percent (0.50%). This grade should keep sedimentation in the siphon to a minimum. 1'-0" of fill (minimum) must cover the siphon pipe along the entire length. The pipe inlet elevation must be higher than the outlet elevation.

If concrete pipe is used, the pipe shall conform to ASTM C 361- (current specification year) unless otherwise specified in the design. The allowable hydrostatic head and fill height must be calculated to use the tables in ASTM C 361.

If smooth, metal pipe is used, the wall thickness will be $\frac{1}{4}$ " for 30" diameter pipe and over and $\frac{3}{16}$ " for pipe under 30" diameter.

External and self weight loads shall be considered in designing miscellaneous hydraulic structures.

ANODES are magnesium billets used for cathodic protection of steel siphon pipes, keeping reactive ions from attacking the pipe. Two anodes will be used at each steel siphon, with both being connected to the lowest pipe. A maximum of 10'-0" will be used for the distance between the pipe and each anode. The anodes are on alternate sides of the pipe and are equidistant from the centerline of survey. One of the anodes is generally placed directly across from the drain box.

The siphon **INLET** is a reinforced concrete structure designed to direct water into the siphon and control erosion underneath the siphon pipe. The inlet usually has only one ditch coming into it, allowing for standardization of the details.

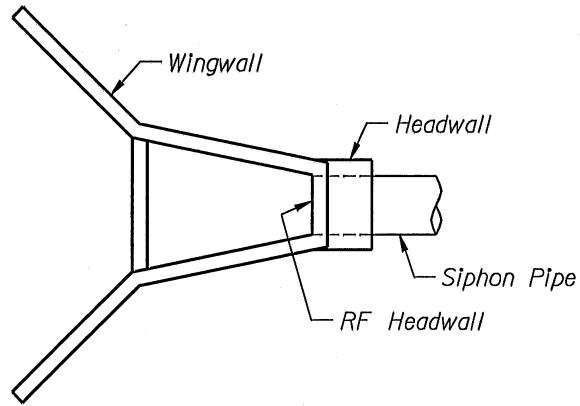

ONE-WAY

The siphon **OUTLET** is similar to the inlet in composition and function. The outlet, however, may incorporate multiple diversion devices to divert water to multiple ditches and/or pipes leading in different directions. Energy dissipators may be incorporated into the outlet.

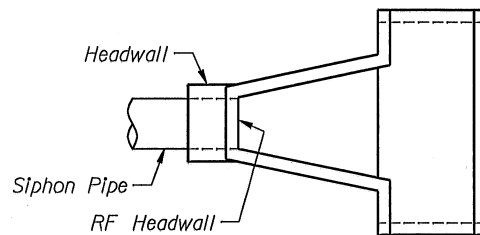

TWO-WAY

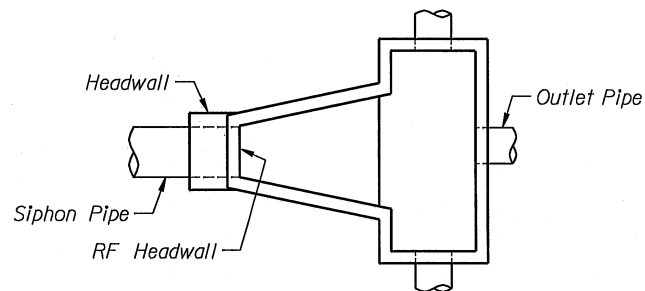

THREE-WAY WITH PIPES

Siphon inlet and outlet structures should incorporate flared walls. Straight walls may be used; however, the structure width will need to be increased as recommended by the hydraulic engineer.

The **INLET REAR FACE OF HEADWALL** and **OUTLET REAR FACE OF HEADWALL** will generally be located on the right-of-way line to make the landowner or ditch operator responsible for maintenance of the inlet and outlet structures, trash guards, and/or approach ditches. Inlet and outlet elevations must match irrigation ditch bottom elevations supplied by the field (or a logical and smooth extension of existing ditch bottom). An exception to this rule allows for the removal of unwanted elevation variations in the irrigation ditch bottom as determined by the Squad Team Leader.

TRASH GUARDS are required on both inlet and outlet structures. The configuration of the trash guards is generally standardized but may vary depending on the structure.

The **DRAIN BOX** is a reinforced concrete structure that houses the drain control valve. The drain box is connected to the siphon by a pipe of smaller diameter. The control valve is attached to this pipe. Siphon draining is done to prevent pipe damage due to freezing water.

The drain box shall be located outside of the **CLEAR ZONE** and in a position relative to the siphon pipe such that no part of the siphon pipe shall be full of water after drainage operations are completed.

Drain boxes are 5'-0" (minimum) in height and may be increased in height in 6" increments as required.

A **DRAIN PIPE** leads from the drain box to daylight in the bottom of the ditch created by the road safety section and the cut slope. If the drain pipe can not daylight within a reasonable distance (usually 400'-0"), a perforated drain pipe with a surrounding drain field is used (usually 200'-0" in length). The drain pipe will need to be specified with a maximum fill height and CR value (if a metal drain pipe is used and the CR value is greater than CR1) as a footnote to the quantities block. If the Project Development Program designs edge drains for the roadway section, a connecting pipe from the drain box to the underdrain pipe may be required instead of a drain pipe or a drain pipe and drain field.

The configuration of the drain box and drain pipe is generally standardized.

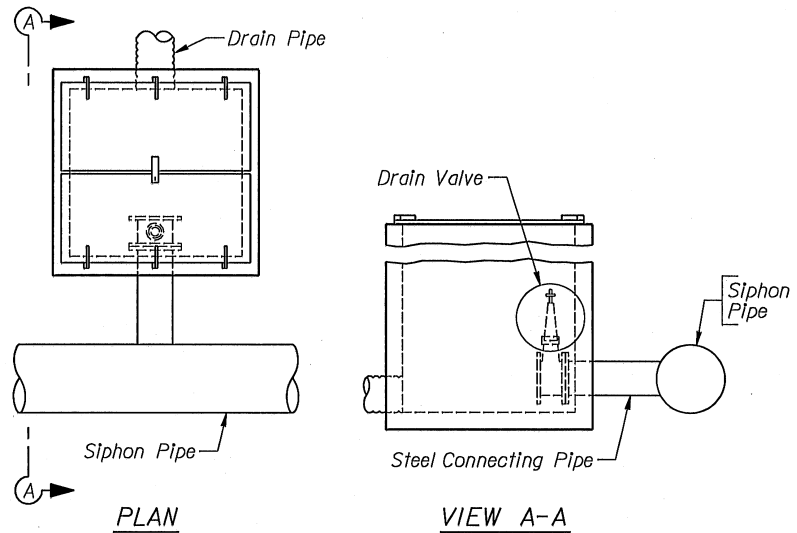

General Design and Detail Information Flumes

The basic geometry; pipe size, material type, and style; and location of a water transport flume is determined by the Hydraulic Section during the course of their analysis and will be included in the Hydraulic Report.

The flume pipe usually consists of jointed straight pipe. The diameter of flume pipe may vary from site to site, but will be the same diameter at any single site. The pipe will be specified as either ASTM A 53, Grade B, for pipes up to 26" (inclusive) in diameter; or as AWWA C200- (current specification year) for pipes larger than 26" in diameter.

The **INLET** and **OUTLET** are reinforced concrete structures designed to support and stabilize the ends of the flume pipe. These structures incorporate ditch-to-pipe transitions that function similar to siphon inlets and outlets.

Depending on the length of the flume and strength of the flume pipe, steel or reinforced concrete **PIERS/BENTS** maybe required at intermediate locations to support the pipe.

Since the flume is not buried, temperature will affect this pipe more than a siphon pipe. Fixed and expansion **BEARINGS** coupled with Dresser type pipe couplings will be used to relieve pipe stresses from expansion and contraction. **SUPPORT RINGS** are required to support the flume pipe at the piers/bents.

Standard Sheets

Name	Description
SIPHON18I01_V8	Inlet/outlet details for 18" pipe
SIPHON18I02_V8	Trash guard details for 18" pipe
SIPHON24I01_V8	Inlet/outlet details for 24" pipe
SIPHON24I02_V8	Trash guard details for 24" pipe
SIPHON30I01_V8	Inlet/outlet details for 30" pipe
SIPHON30I02_V8	Trash guard details for 30" pipe
SIPHON36I01_V8	Inlet/outlet details for 36" pipe
SIPHON36I02_V8	Trash guard details for 36" pipe
SIPHONDBOX_V8	Siphon drain box details
SIPHONMISC_V8	Miscellaneous siphon details (Drain box cover, ladder rung, O-ring details, etc.)

Cells

Name	Description
SI0BXE	Elev of Drain Box
SI0BXP	Plan of Drain Box
SI0COUPH	Siphon Pipe Coupling Details – Horizontal
SI0COUPV	Siphon Pipe Coupling Details - Vertical
SI0ELE	Siphon Inlet or Outlet Elev
SI0PLN	Siphon Inlet or Outlet Plan