

<b>WYOMING DEPARTMENT OF TRANSPORTATION</b>
<b>ROAD DESIGN MEMORANDUM #10</b>
<b>DATE OF ISSUE: May 1, 2023</b>



Approved by: Christina Spindler  
Christina Spindler, P.E.  
Highway Development Engineer

Digitally signed by Christina Spindler  
Date: 2023.10.26 16:25:25 -06'00'

Issued by: Project Development, WYDOT, Cheyenne

<b>GENERAL TOPIC: REDUCED FENCE HEIGHTS</b>
<b>SUBJECT: 42-INCH FENCE HEIGHT REQUESTS</b>

## General

In cooperation with the Wyoming Game & Fish Department (WGFD), WYDOT changed Operating Policy (OP) 19-04, Fences and Cattle Guards, in 2019 to allow a lower minimum fence height of 42” in select areas upon request and recommendation from the WGFD on primary and secondary highways. The policy also requires the WGFD to obtain written permission from the private landowner(s) involved and any lessee involved that may be grazing livestock.

Although WGFD personnel are encouraged to work with the resident engineer to acquire permissions, it is ultimately the responsibility of the WGFD to meet with the landowners and acquire the permissions. WGFD personnel are better equipped to explain to a landowner why a certain fence is desired and answer wildlife related questions.

WYDOT’s standard 45” high wildlife friendly fence remains as shown in the standard plans. The use of this fence does not require the WGFD to get adjacent landowner permission. Only use the 42” height fence when specifically requested by the WGFD and when meeting the requirements of OP 19-04. The request for the lower fence height would typically come in the WGFD’s written response to the Project Development plan issuances.

Since a 42” fence is not part of WYDOT standard plans, a detail will need to be included in the plans for the lower fence configuration(s) selected as shown on the signed permission form(s). The landowner permission form requires the landowner to choose one of two configurations shown on the form below.

### Fence Request Form



Wyoming Department of Transportation (WYDOT)  
and  
Wyoming Game and Fish Department (WGFD)



DATE: \_\_\_\_\_

WYDOT PROJECT NUMBER: \_\_\_\_\_

ROAD DESIGNATION: \_\_\_\_\_

RM-RM: \_\_\_\_\_ SIDE OF HIGHWAY: \_\_\_\_\_ COUNTY: \_\_\_\_\_

LOCATION: Sections \_\_\_\_\_ Township \_\_\_\_\_ Range \_\_\_\_\_ WYDOT Station Range: \_\_\_\_\_

EXISTING FENCE (height, number of strands, bottom gap): \_\_\_\_\_

As part of the above noted WYDOT project, all or some of the fencing along the highway right-of-way is scheduled to be replaced. In an effort to improve wildlife movement in the area, WYDOT and WGFD are seeking your permission to install a 42" high fence along the highway right-of-way adjacent to your property as part of the project. This form will be used for tracking and monitoring purposes only, and does not place any liability on the landowner. Please check landowner fence option preference below:

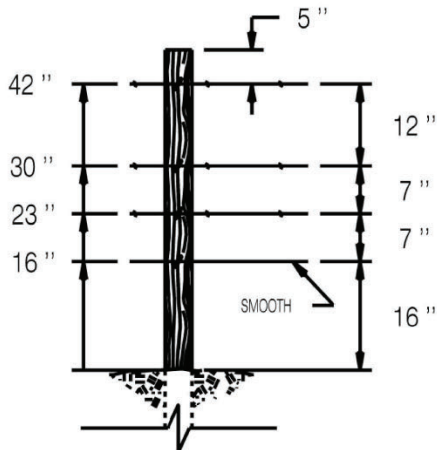

4 wire fence  
(3 barbed wire & 1 Smooth)

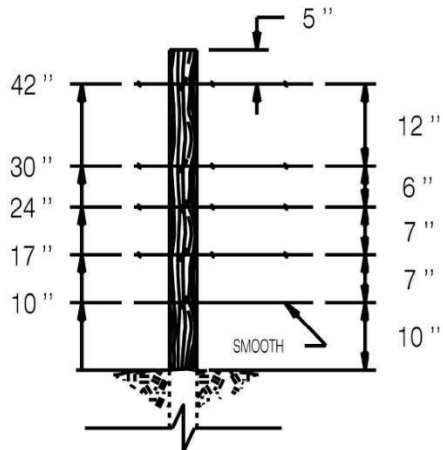

5 wire fence  
(4 barbed wire & 1 Smooth)

\_\_\_\_\_  
Landowner Phone

\_\_\_\_\_  
Lessee (if applicable) Phone